

J.L. WINGERT CO.

Specification Sheet COMPACT GLYCOL FEED SYSTEM MODEL CGL[]

SS161006.E 01/25

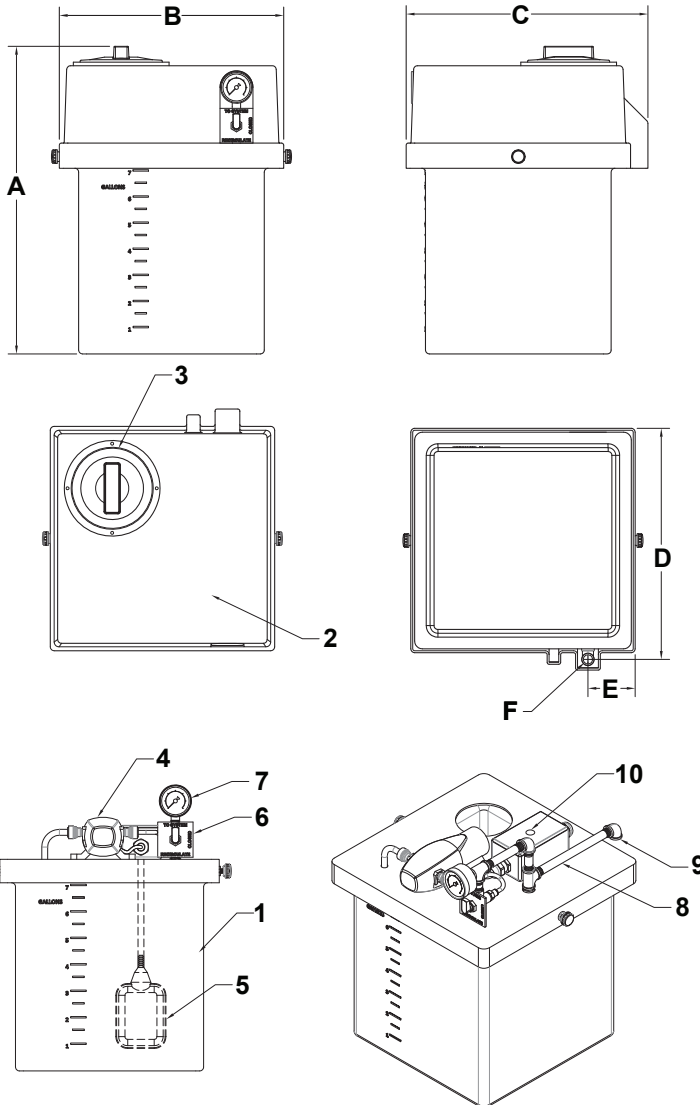

SPECIFICATIONS:

KEY	MODEL	DESCRIPTION
1	TANK:	
	CGL7	7 Gallon polyethylene tank with gallon markings
	CGL10	10 Gallon polyethylene tank with gallon markings
	CGL17	17 Gallon polyethylene tank with gallon markings
2	COVER:	
	ALL	Polyethylene cover with integrated fill funnel
3	MANWAY:	
	ALL	4" Vented manway
4	PUMP:	
	ALL	1.0 GPM pump with integrated pressure switch, suction check valve and discharge check valve
5	LOW LEVEL SWITCH:	
	ALL	Low level switch to stop pump upon low level
6	SYSTEM VALVE:	
	ALL	3-way ball valve, select between recirculate, closed or system
7	PRESSURE GAUGE:	
	ALL	2" 0-60 PSI pressure gauge
8	DISCHARGE MANIFOLD:	
	ALL	304 Sch40 stainless steel pipe and fittings with brass 60 PSI pressure relief valve
9	DISCHARGE CONNECTION:	
	ALL	1/2" MNPT
10	FUSE HOLDER:	
	ALL	2 Amp slow blow fuse
ELECTRICAL:		115VAC/1Ph/60Hz, 8ft Nema 5-15P power cord
MAX PRESSURE:		80 PSI (3.1 BAR)
MAX TEMPERATURE:		110 °F (43.3 °C)
FACTORY SETTING:		cut-in 45 PSI cut-out 57 PSI

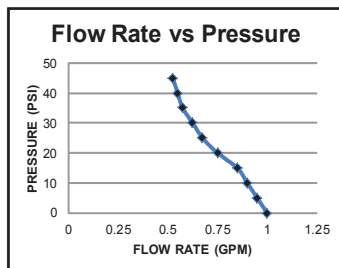

DIMENSIONS:

	CGL7	CGL10	CGL17
A	19 7/8"	25 7/8"	37 7/8"
B	14 1/2"	14 1/2"	14 1/2"
C	15 5/8"	15 5/8"	15 5/8"
D	14 15/16"	14 15/16"	14 15/16"
E	3 1/16"	3 1/16"	3 1/16"
F	1/2" MNPT	1/2" MNPT	1/2" MNPT
Weight	20 lbs. approx.	23 lbs. approx.	29 lbs. approx.

Note: All dimensions are +/- 1/8". All weights are approximate. All dimensions are subject to change without notice.

MANUFACTURING: Mixers, Bypass Feeders, Filter Feeders, Bromine Feeders, Sample Coolers, Sludge Traps, Separators, Separator Systems, Tank Stands, Tank Package Systems, Glycol Feed Systems, Coupon Racks, Control Stations, NEMA Enclosures, Custom Packaged Systems and Specialty Welding

P.O. Box 6207 | Garden Grove, CA 92846-6207 | 11800 Monarch St. | Garden Grove, CA 92841-2113 | Phone (714) 379-5519 | Fax (714) 379-5549
Northern California Region | Phone (510) 487-5310 | Southwest Region | Phone (602) 470-1015 | Email: customerservice@jllwingert.com

www.jllwingert.com