



COMPACT GLYCOL FEED SYSTEMS

OPERATION & MAINTENANCE MANUAL



PLEASE RECORD THE FOLLOWING DATA

(Information is located on the product label or packing slip)

Model Number: _____

Pressure Setting: _____

Serial Number: _____

Installation Date: _____

Installation Location / Application: _____

The above information will help when ordering replacement parts and accessories for your Wingert Compact Glycol Feed System.

J.L. WINGERT CO. MANUFACTURED PRODUCTS

Mixers, Bypass Feeders, Filter Feeders, Bromine Feeders, Sample Coolers, Sludge Traps, Separators, Separator Systems, Tank Stands, Tank Package Systems, Glycol Feed Systems, Coupon Racks, Control Stations, NEMA Enclosures, Custom Packaged Systems and Specialty Welding

P.O. Box 6207 • Garden Grove, CA 92846-6207 / 11800 Monarch St. • Garden Grove, CA 92841-2113 • Phone (714) 379-5519 • Fax (714) 379-5549
Northern California Region • Phone (510) 487-5310 • Southwest Region • Phone (602) 470-1015 • Email: customerservice@jllwingert.com

www.jllwingert.com

CONTENTS:	PAGES
1.0 INTRODUCTION	2
2.0 WARRANTY	2
3.0 UNPACKING	2
3.1 CHECKLIST	3
4.0 SAFETY	3
4.1 SAFETY HIGHLIGHTS	4
5.0 LOCATION AND ENVIRONMENT	5
6.0 INSTALLATION	5
7.0 START-UP AND OPERATING PROCEDURE	5
8.0 REFILLING PROCEDURE	6
9.0 PRESSURE SWITCH ADJUSTMENT PROCEDURE	6
10.0 WIRING PROCEDURE FOR THE AUDIBLE ALARM PANEL (AL)	7
11.0 TROUBLESHOOTING	8

1.0 INTRODUCTION

These compact, automated systems deliver a comprehensive package at a modest cost. These units are available in three standard sizes with optional alarm and wall mount bracket.

2.0 WARRANTY

Wingert Glycol Feed Systems are warranted against manufacturing defects in material and workmanship for one year from the date of shipment. Applications outside the service for which the product is designed will automatically void any warranty. J.L. Wingert Co. will repair or replace a defective unit when returned to the factory with transportation prepaid. Final determination will be made upon inspection. J.L. Wingert Co. assumes no liability for labor and/or other expenses in making repairs or adjustments. All replacements will be F.O.B. factory. There are no other implied or expressed warranties.

The pump is not manufactured by J.L. Wingert Co. and thus is warranted by the original manufacturer. Repair or replacement is contingent upon inspection and determination by the original manufacturer. Their findings are final and beyond our control.

3.0 UNPACKING

Unit is not intended to be stored or installed outdoors. Wingert Glycol Feed Systems are assembled and ready for installation. Inspect packaging upon receipt for any damage. Unpack and inspect the product for physical damage and verify that goods received correlate with the packing list. The factory must be notified within 3 days of receipt of any discrepancies. If any product is damaged due to freight handling, contact the freight carrier to register a claim and contact the factory immediately for further assistance.

NOTE: Most freight carriers only allow 3-5 days after receipt of goods to file a freight claim.

3.1 CHECKLIST

Using the table below, verify that you have received the correct product for your application.

CGL [] / []

OPTIONS	
-AL	95 decibel audible alarm with silence switch and remote dry contact on low level, mounted in a control panel
-CWB	Wall bracket for Compact Glycol Feed System

TANK VOLUME	
7	7 GALLONS
10	10 GALLONS
17	17 GALLONS

BASE MODEL	
CGL	Compact Glycol Feed System

- MAXIMUM OPERATING PRESSURE: 80 PSI**
- MAXIMUM OPERATING TEMPERATURE: 110°F**
- FACTORY STANDARD CUT-IN SETTING: 45 PSI**
- FACTORY STANDARD CUT-OUT SETTING: 57 PSI**

NOTE: Custom systems are offered when your needs are not met by the standard models. Consult the factory at customerservice@jllwingert.com or (714) 379-5519 for assistance.

4.0 SAFETY

J.L. Wingert Co. manufactured equipment is designed and built with safety in mind. However, proper installation and operation is necessary for your overall safety.

DO NOT INSTALL, OPERATE OR REPAIR THIS EQUIPMENT WITHOUT READING THIS MANUAL AND THE SAFETY PRECAUTIONS CONTAINED THROUGHOUT.

BE SURE THAT ALL INSTALLATION, OPERATION, MAINTENANCE AND REPAIR PROCEDURES ARE PERFORMED BY QUALIFIED INDIVIDUALS ONLY.

4.1 SAFETY HIGHLIGHTS

Read and understand the following safety highlights.



ELECTRICAL SHOCK CAN KILL

Do not perform any services without first disconnecting electrical service to all equipment. High voltage electrical power is present inside the electrical enclosure.

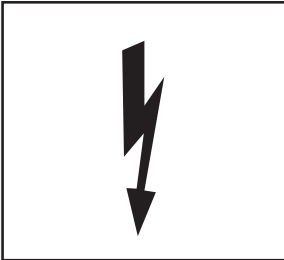

ELECTRICAL SERVICE CONNECTION

Install and ground equipment in accordance with the U.S. National Electrical Code, all local codes and the manufacturer's recommendations. Electrical installation and repair should be performed by a qualified individual only.

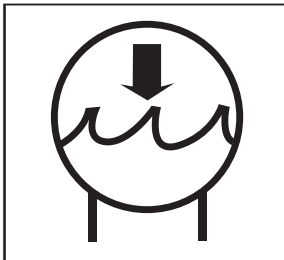

WATER PRESSURE INSIDE THE UNIT

See design specification for maximum operating pressure. Do not perform maintenance or repair without first releasing the water pressure and draining the fluid from the unit.



EQUIPMENT IDENTIFICATION LABEL

Identification label provides equipment information. Be sure the voltage, phase and frequency of the input power are as specified on the Equipment Identification Label and conform with your local code and requirements.

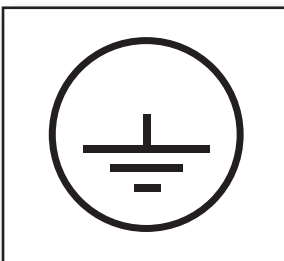

GROUND CONNECTION

Input power and ground system for safe operation of the equipment. See your local and National Electrical Codes for proper grounding methods.

5.0 LOCATION AND ENVIRONMENT

Although the junction box is weatherproof and the pump is sealed, the Compact Glycol Feed System should be stored and installed indoors. If the unit needs to be installed outdoors contact J. L. Wingert Co. at customerservice@jllwingert.com or 714-379-5519 for assistance.

6.0 INSTALLATION

MOUNTING

The Compact Glycol Feed System can be placed directly on the floor. When using the optional compact wall mounting bracket, (CWB), use ¼" x 2 ½" lag bolts or anchors to fasten the bracket to the wall. The mounting holes are 16" on center to allow for mounting to the studs. Wingert does not recommend installing the CWB with drywall anchors. The CWB can be mounted directly to a masonry wall or the building studs as long as the studs or wall can support the weight.

PLUMBING

Install an isolation ball or gate valve between discharge point of the glycol feed system and the system it is feeding into.

WIRING

Wingert Compact Glycol Feed Systems come with a 14 gauge, 115 VAC power cord. Plug the Glycol Feed System into a 115 VAC, 15 Amp minimum receptacle. **NOTE:** Check the local code to see if the receptacle needs to be GFCI.

7.0 START-UP AND OPERATING PROCEDURE

- 1) The Compact Glycol Feed System is supplied with the 3-Way valve in the closed position. Verify that it has not shifted during handling and is still in the "CLOSED" position. If shifted, turn the knob to the "CLOSED" position.
- 2) Connect the ¼" FNPT discharge to an isolation valve on the hydronic system using hose or tubing rated for the systems temperature and pressure. The isolation valve cannot be a check valve or pressure reducing valve. J. L. Wingert Co. recommends using a ball valve.
- 3) Fill the tank with the appropriate amount of the desired glycol solution by removing the 4" manway on the top cover. The cover does not need to be removed to fill the tank. Once full, replace the manway.
- 4) Plug the power cord into the receptacle. **NOTE:** Check the local code to see if the receptacle needs to be a GFCI receptacle.
- 5) Turn the knob on the 3-Way valve to the "RECIRCULATE" position. The pump should turn on and start recirculating the glycol mixture back into the tank.

7.0 START-UP AND OPERATING PROCEDURE (Continued)

- 6) Once the pump is pumping the glycol mixture and there is no air in the line, turn the knob on the 3-Way valve to the "TO SYSTEM" position and open the hydronic system isolation valve. The pump will start pumping until the pressure switch senses the desired cut-out pressure. The pump may cycle rapidly a number of times while the system pressure stabilizes and air is removed from the system. The cycling will stop once the system pressure is greater than or equal to the pressure switch's cut-out pressure.
- 7) Inspect the connection of the hose or tubing to the glycol feed system as well as the connection to the hydronic system to verify that there are no leaks.
- 8) The compact glycol feed system is now fully operational and will automatically turn on when the pressure in the hydronic system falls below the pressure switch's cut-in pressure. The compact glycol feed system will also automatically turn off when the fluid level fails below 1½ gallons. Please see **Section 10.0** for the installation of the optional audible alarm panel, (AL). For instructions on adjusting the pressure switch refer to **Section 9.0**.

8.0 REFILLING PROCEDURE

- 1) Turn the knob on the 3-Way valve to the "CLOSED" position.
- 2) Open the 4" manway on the cover and fill the tank with the required amount of the glycol mixture and replace the manway.
- 3) Turn the knob on the 3-Way valve to the "RECIRCULATE" position to mix the solution.
- 4) Once the solution has been thoroughly mixed, turn the knob on the 3-Way valve to the "TO SYSTEM" position. The system will once again operate in automatic mode.

9.0 PRESSURE SWITCH ADJUSTMENT PROCEDURE

- 1) Turn the knob on the 3-Way valve to the "CLOSED" position.
- 2) Remove the cover for the Compact Glycol Feed System by removing the side threaded knobs and lifting straight up.
3. Remove the pump head cover by unscrewing the phillips screw, as shown in **Figure 1** below.



Figure 1

9.0 PRESSURE SWITCH ADJUSTMENT PROCEDURE (Continued)

- 4) Using a permanent marker, mark the vertical position of the phillips screw. Turn the phillips screw clockwise to increase the Cut-Out pressure and counterclockwise to decrease the Cut-Out pressure.

See **Figure 2** below as a reference for the adjustment screw. **NOTE: The Cut-In pressure cannot be adjusted. It is approximately 12 PSI less than the Cut-Out pressure.**

- 5) Replace the pump head cover, then the Compact Glycol Feed System Cover, insert the threaded knobs and finally turn the 3-Way valve to the "TO SYSTEM" position.



Mark a vertical line for reference when adjusting the pressure switch.

Figure 2

10.0 WIRING PROCEDURE FOR THE AUDIBLE ALARM PANEL (AL)

- 1) Unplug the power cord for the Compact Glycol Feed System.
- 2) Remove the cover by removing the two threaded knobs on the side and lifting straight up.
- 3) With the cover removed, remove the two screws on the junction box cover.
- 4) Remove the junction box cover and unplug the power cord's black wire from the fuse holder. Next, remove the wire nut on the white wires, green wires, and blue wire. Do not disconnect the brown wire.
- 5) Loosen the nut on the rear cord grip holding the power cord in place and remove the power cord.
- 6) Hang the Audible Alarm Panel, (AL), with #8 screws. **NOTE:** the cable to connect the control panel to the glycol feed system is approximately 6 ½ feet long.
- 7) Insert the free end of the power cable from the control panel into the rear cord grip on the junction box.
- 8) Connect the black wire for the power cable to the fuse holder, then the white wire to the white wire, green wire to the green wire and the red wire to the blue wire, as shown in **Figure 3 on page 8.**

10.0 WIRING PROCEDURE FOR THE AUDIBLE ALARM PANEL (AL) (Continued)

- 9) Tighten the nut on the cord grip, reinstall the junction box cover, and reinstall the cover for the Compact Glycol Feed System tightening the threaded knobs on the sides.
- 10) If the dry contact feature is not being used, the cable can be disconnected by unscrewing the circular connector. If using the dry contact feature; connect the two cables to the remote alarming device (smart home, building DCS, etc.) **NOTE:** This is a non-powered contact closure; external power may be required for the remote alarm device.

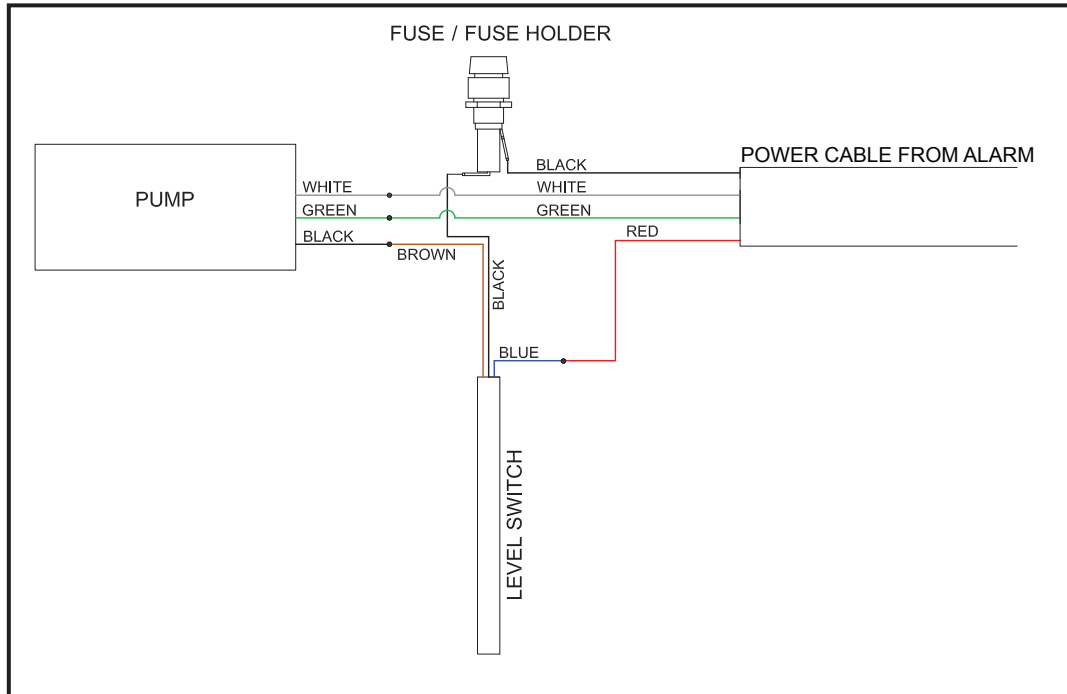

Figure 3

11.0 TROUBLESHOOTING

Symptom

Pump will not start	Fluid level in tank is low	Refill the tank with more fluid. See Section 8.0 for filling instructions, then plug the power cord back in.
	Blown fuse	Unplug the power cord from the wall. Remove the cover for the Compact Glycol Feed System. Locate the fuse holder, and remove and replace the fuse with a 2 Amp slow blow fuse.
	Power cord is unplugged	Plug power cord back into the correct outlet.
	GFCI outlet is tripped	Unplug the power cord from the outlet. Press the Reset button on the outlet and then plug the power cord in.
	Incorrect pressure setting	Turn the 3-Way valve to the "RECIRCULATE" position to test the pump. If the pump does turn on, refer to Section 9.0 for pressure setting instructions.
	Pump failure	Turn the 3-Way valve to the "RECIRCULATE" position to test the pump. If the pump does not turn on, contact factory for replacement.
Pump is cycling on and off repeatedly	There is air in the system	Install an air release valve to automatically purge the air in the system.
	Leak in the system	Inspect the system and repair the leaks.
Pump runs continuously	3-Way valve is in the "RECIRCULATE" position	Turn the 3-Way valve to the "TO SYSTEM" position.
	Pressure switch has failed in the closed position	Replace the pump and pressure switch assembly.
	Leak in the system	Inspect the system and repair the leaks.