



Specification Sheet
RIGID PE HINGED COVER WITH MOUNTING PAD
MODEL RC[]-PB-H

SS132004.B 02/17

SPECIFICATIONS

KEY	DESCRIPTION
1	COVER: Polyethylene rigid covers are constructed from 1/2" thick polyethylene with polypropylene bolted hinges and equipment mounting pad

DIMENSIONS

MODEL	A	B	C
RC10-PB-H	15 1/2" diameter	5"	6"
RC15-PB-H	17" diameter	5 1/2"	6"
RC30-PB-H	21" diameter	7"	6"
RC55-PB-H	25 1/2" diameter	8 1/2"	8"
RC65-PB-H	25" diameter	8 1/2"	8"
RC80-PB-H	27" diameter	9"	8"
RC100-PB-H	30" diameter	10"	10"
RC150-PB-H	34" diameter	11 1/2"	10"

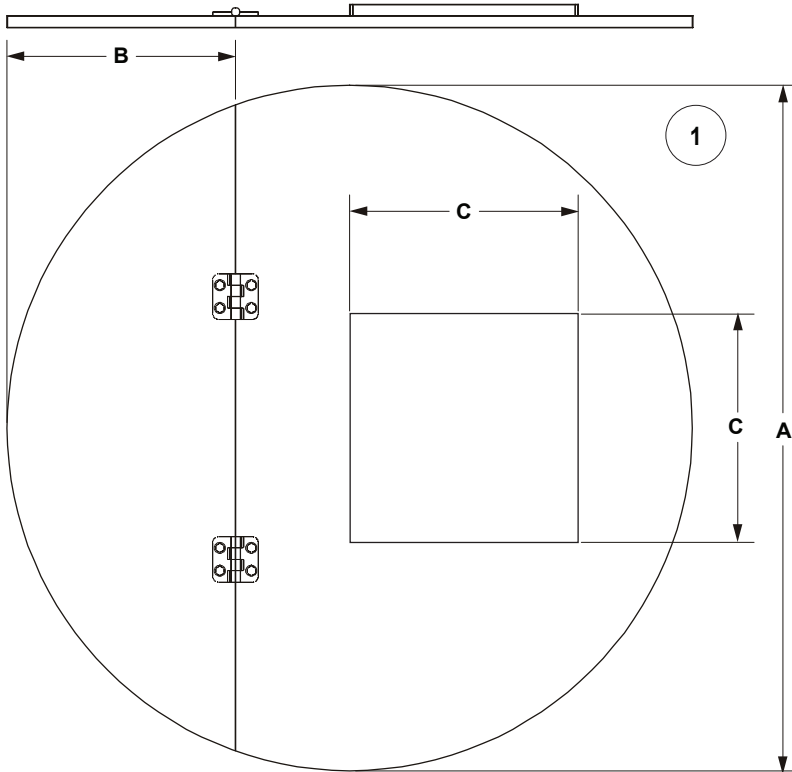

Note: All dimensions are +/- 1/8". All weights are approximate. All dimensions are subject to change without notice.

MANUFACTURING: Mixers, Bypass Feeders, Filter Feeders, Bromine Feeders, Sample Coolers, Sludge Traps, Separators, Separator Systems, Tank Stands, Tank Package Systems, Glycol Feed Systems, Coupon Racks, Control Stations, NEMA Enclosures, Custom Packaged Systems and Specialty Welding

P.O. Box 6207 | Garden Grove, CA 92846-6207 | 11800 Monarch St. | Garden Grove, CA 92841-2113 | Phone (714) 379-5519 | Fax (714) 379-5549
 Northern California Region | Phone (510) 487-5310 | Southwest Region | Phone (602) 470-1015 | Email: customerservice@jllwingert.com

www.jllwingert.com