



Specification Sheet
OVERFLOW BASINS WITH 3" FLANGE
MODEL []-OF

SS130027.C 02/17

DIMENSIONS

GALLONS	A	B	C	WEIGHT
490	31"	72" diameter	65" diameter	72 lbs. approx.
700	42"	72" diameter	65" diameter	105 lbs. approx.
875	34"	90" diameter	83" diameter	129 lbs. approx.
1420	54"	90" diameter	83" diameter	178 lbs. approx.
1440	85"	72" diameter	65" diameter	218 lbs. approx.
2090	79"	90" diameter	83" diameter	330 lbs. approx.
3370	73"	118" diameter	111" diameter	528 lbs. approx.
59309	128"	118" diameter	111" diameter	1400 lbs. approx.

NOTE: Place gallons inside [] for complete part number.

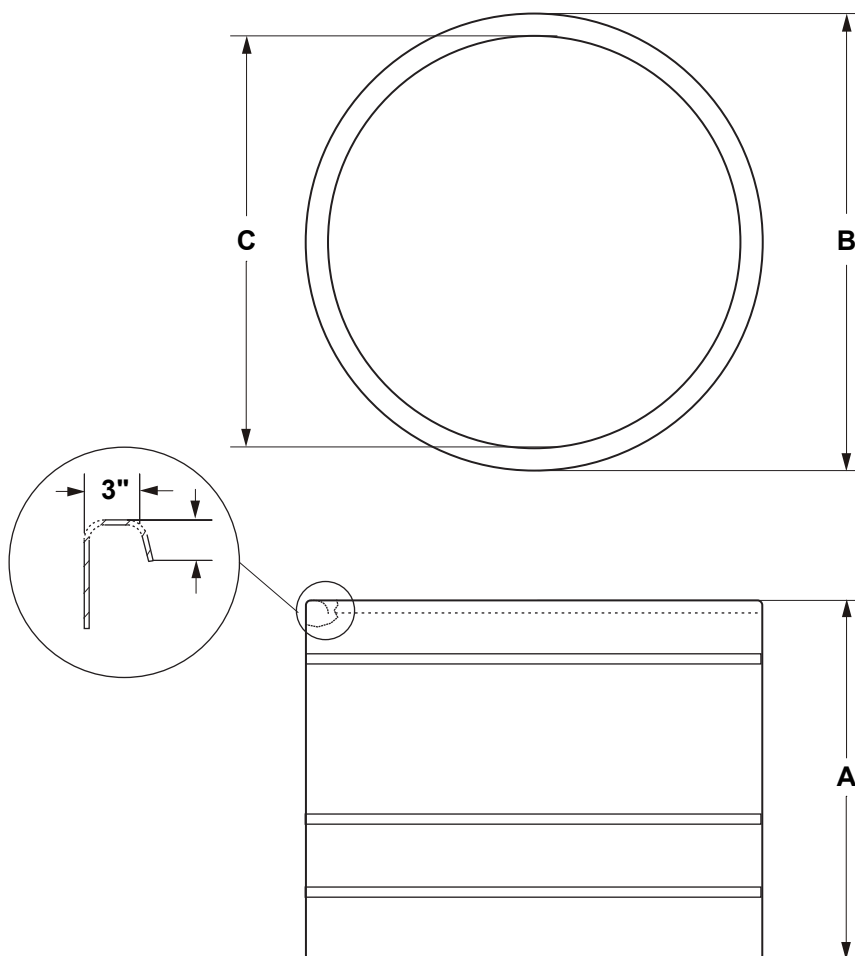

Note: All dimensions are +/- 1/8". All weights are approximate. All dimensions are subject to change without notice.

MANUFACTURING: Mixers, Bypass Feeders, Filter Feeders, Bromine Feeders, Sample Coolers, Sludge Traps, Separators, Separator Systems, Tank Stands, Tank Package Systems, Glycol Feed Systems, Coupon Racks, Control Stations, NEMA Enclosures, Custom Packaged Systems and Specialty Welding

P.O. Box 6207 | Garden Grove, CA 92846-6207 / 11800 Monarch St. | Garden Grove, CA 92841-2113 | Phone (714) 379-5519 | Fax (714) 379-5549
 Northern California Region | Phone (510) 487-5310 | Southwest Region | Phone (602) 470-1015 | Email: customerservice@jllwingert.com

www.jllwingert.com