

J.L. WINGERT CO.

Specification Sheet LOW LEVEL SWITCH ASSEMBLY OPTION K

SS102208.D 02/17

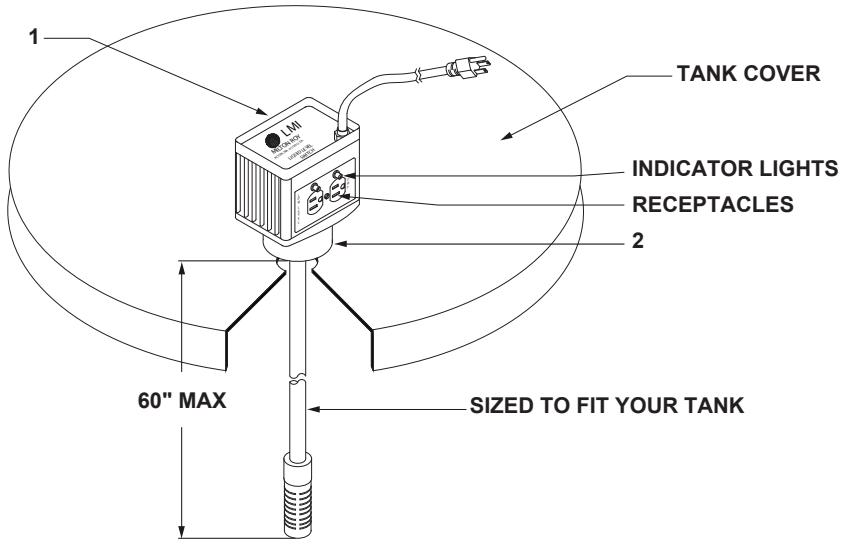

SPECIFICATIONS

| KEY | OPTION | DESCRIPTION |
|-----|--------|--------------------------------------------------------------------------------------------------------------------------------------------------------------------------------------------------------------------|
| 1 | K | SWITCH ASSEMBLY: 115V / 60 Hz with dual control receptacles that have visual display status lights, 10 amp relays and receptacles encased in chemical resistant glass with reinforced polypropylene housing |
| 2 | | MOUNT: Level switch is mounted with stainless steel hardware with neoprene gasket (option is valid on up to 60" deep tank) |

TYPICAL USES

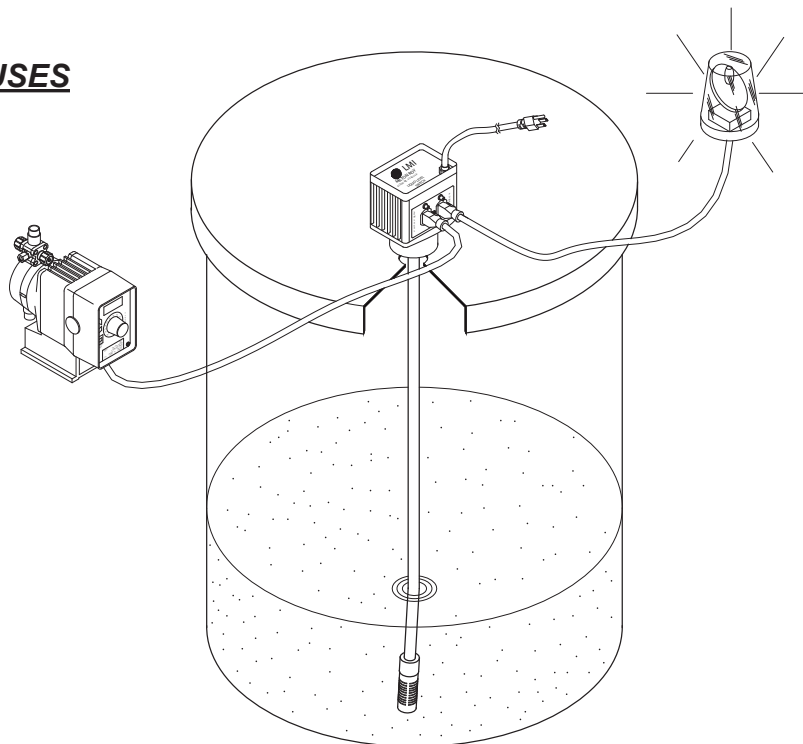

Note: All dimensions are +/- 1/8". All weights are approximate. All dimensions are subject to change without notice.

MANUFACTURING: Mixers, Bypass Feeders, Filter Feeders, Bromine Feeders, Sample Coolers, Sludge Traps, Separators, Separator Systems, Tank Stands, Tank Package Systems, Glycol Feed Systems, Coupon Racks, Control Stations, NEMA Enclosures, Custom Packaged Systems and Specialty Welding

P.O. Box 6207 | Garden Grove, CA 92846-6207 / 11800 Monarch St. | Garden Grove, CA 92841-2113 | Phone (714) 379-5519 | Fax (714) 379-5549
Northern California Region | Phone (510) 487-5310 | Southwest Region | Phone (602) 470-1015 | Email: customerservice@jllwingert.com

www.jllwingert.com