

# J.L. WINGERT CO.

## Specification Sheet HIGH OR LOW SIDE MOUNT LEVEL SWITCH OPTION 00

SS102207.D 02/17

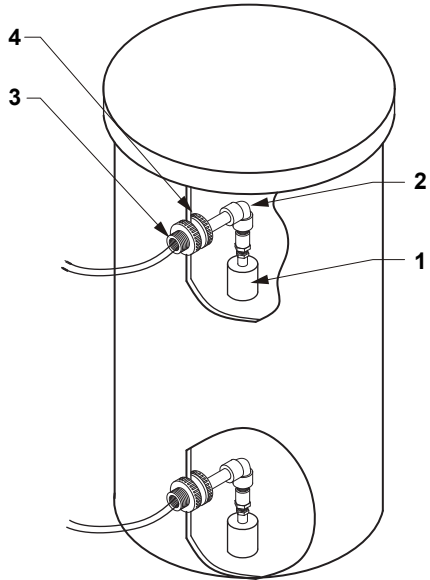

**SPECIFICATIONS**

KEY	PART	DESCRIPTION
1	<b>00</b>	<b>LEVEL SWITCH:</b> Constructed of polypropylene with maximum switch amp load of 10 amps @115V (switch normally open or normally closed by reversing float orientation)
2		<b>ELBOW:</b> Threaded and constructed of Sch. 80 PVC
3		<b>ADAPTER:</b> ADAPTER: Constructed of gray Sch. 80 PVC with both threaded and slip connections
4		<b>GASKET:</b> Standard gasket material is EPDM

**TYPICAL USES**

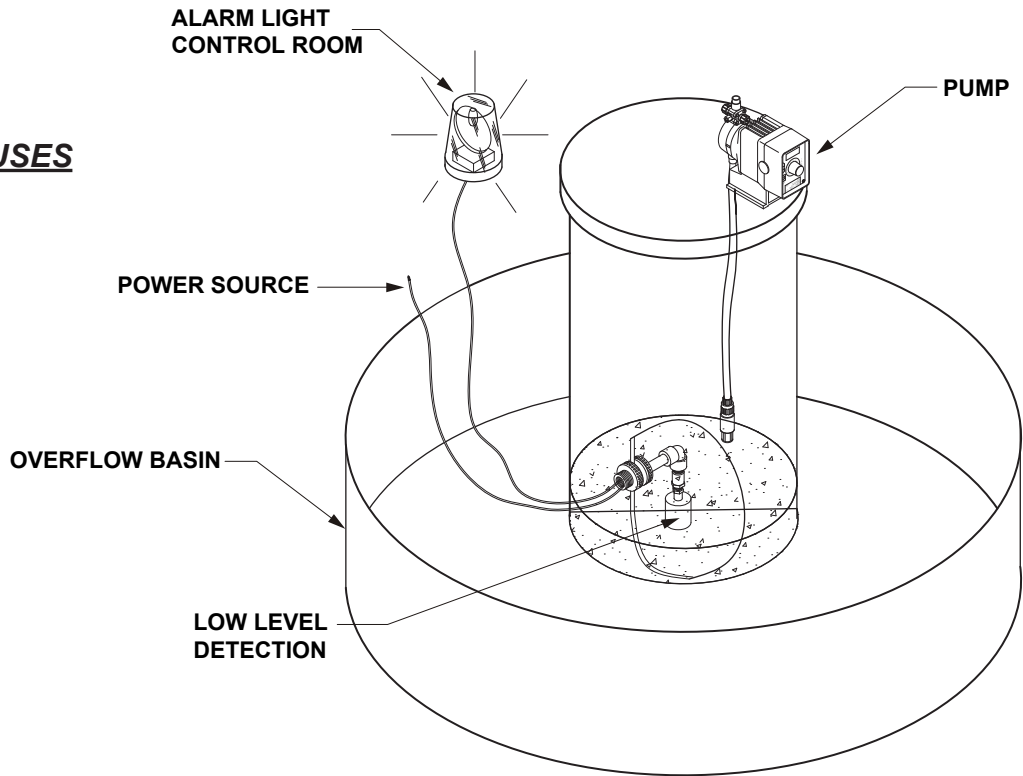

**Note: All dimensions are +/- 1/8". All weights are approximate. All dimensions are subject to change without notice.**