

J.L. WINGERT CO.

Specification Sheet Y-STRAINERS OPTION []

SS102206.D 02/17

INSTALLATION
NIPPLE

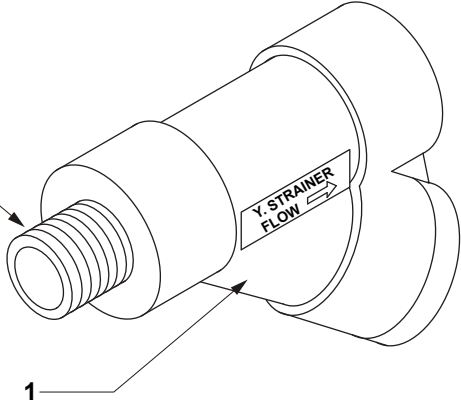

SPECIFICATIONS

KEY	PART	DESCRIPTION
1	O	1/2" PVC Y-STRAINER ASSEMBLY: Constructed of gray Sch. 80 PVC with a standard 1/32" perforated screen and viton o-ring seals
	DD	3/4" PVC Y-STRAINER ASSEMBLY: Constructed of gray Sch. 80 PVC with a standard 1/32" perforated screen and viton o-ring seals

TYPICAL USES

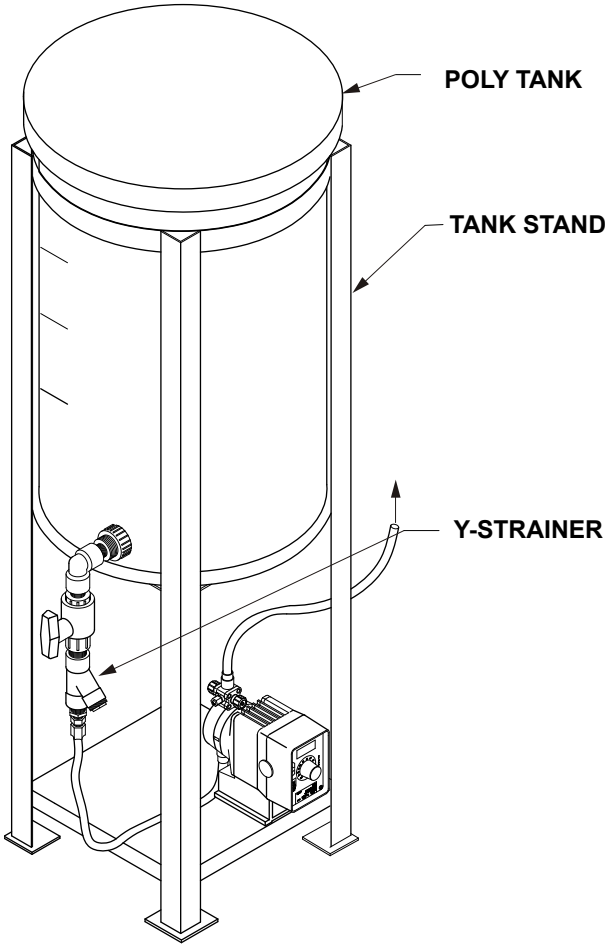

Note: All dimensions are +/- 1/8". All weights are approximate. All dimensions are subject to change without notice.