

J.L. WINGERT CO.

Specification Sheet PVC / POLYPROPYLENE TANK ADAPTERS OPTION []

SS102201.D 02/17

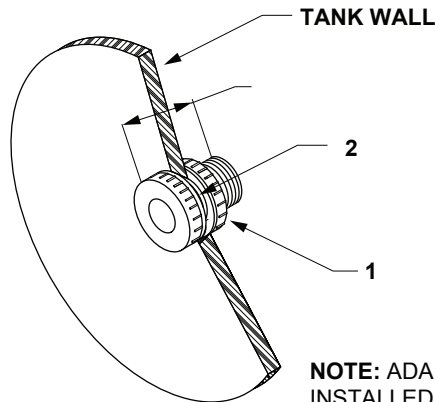

NOTE: ADAPTERS ARE TYPICALLY INSTALLED THREADS OUT. ADAPTER MAY BE REVERSED FOR SOCKET WELD.

TYPICAL USES

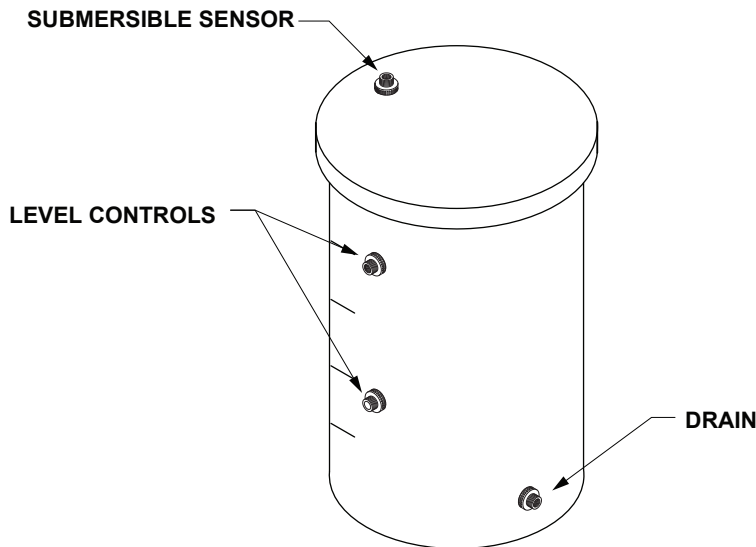

SPECIFICATIONS

KEY	PART	DESCRIPTION
1	R	1/4" PVC TANK ADAPTER: Constructed of gray Sch. 80 PVC with both threaded and slip connections
	S	1/2" PVC TANK ADAPTER: Constructed of gray Sch. 80 PVC with both threaded and slip connections
	T	3/4" PVC TANK ADAPTER: Constructed of gray Sch. 80 PVC with both threaded and slip connections
	U	1" PVC TANK ADAPTER: Constructed of gray Sch. 80 PVC with both threaded and slip connections
	V	1 1/2" PVC TANK ADAPTER: Constructed of gray Sch. 80 PVC with both threaded and slip connections
	W	2" PVC TANK ADAPTER: Constructed of gray Sch. 80 PVC with both threaded and slip connections
	X	3" PVC TANK ADAPTER: Constructed of gray Sch. 80 PVC with both threaded and slip connections
	FF	1/2" POLYPROPYLENE TANK ADAPTER: Constructed of natural polypropylene with both threaded and slip connections
	HH	3/4" POLYPROPYLENE TANK ADAPTER: Constructed of natural polypropylene with both threaded and slip connections
	JJ	1" POLYPROPYLENE TANK ADAPTER: Constructed of natural polypropylene with both threaded and slip connections
2	I	2" POLYPROPYLENE TANK ADAPTER: Constructed of natural polypropylene with both threaded and slip connections
		GASKET: Standard gasket material is EPDM

DIMENSIONS

KEY	A
OPTION R	1 1/8"
OPTION S	2"
OPTION T	2"
OPTION U	2"
OPTION V	2 1/4"
OPTION W	2 1/4"
OPTION X	4 5/8"
OPTION FF	2"
OPTION HH	2"
OPTION JJ	2"
OPTION I	2 1/4"

Note: All dimensions are +/- 1/8". All weights are approximate. All dimensions are subject to change without notice.

MANUFACTURING: Mixers, Bypass Feeders, Filter Feeders, Bromine Feeders, Sample Coolers, Sludge Traps, Separators, Separator Systems, Tank Stands, Tank Package Systems, Glycol Feed Systems, Coupon Racks, Control Stations, NEMA Enclosures, Custom Packaged Systems and Specialty Welding

P.O. Box 6207 | Garden Grove, CA 92846-6207 | 11800 Monarch St. | Garden Grove, CA 92841-2113 | Phone (714) 379-5519 | Fax (714) 379-5549
Northern California Region | Phone (510) 487-5310 | Southwest Region | Phone (602) 470-1015 | Email: customerservice@jllwingert.com

www.jllwingert.com