

# J.L. WINGERT CO.

## Specification Sheet 50 GALLON OVERFLOW BASIN MODEL OF-50

SS072009.B 02/17

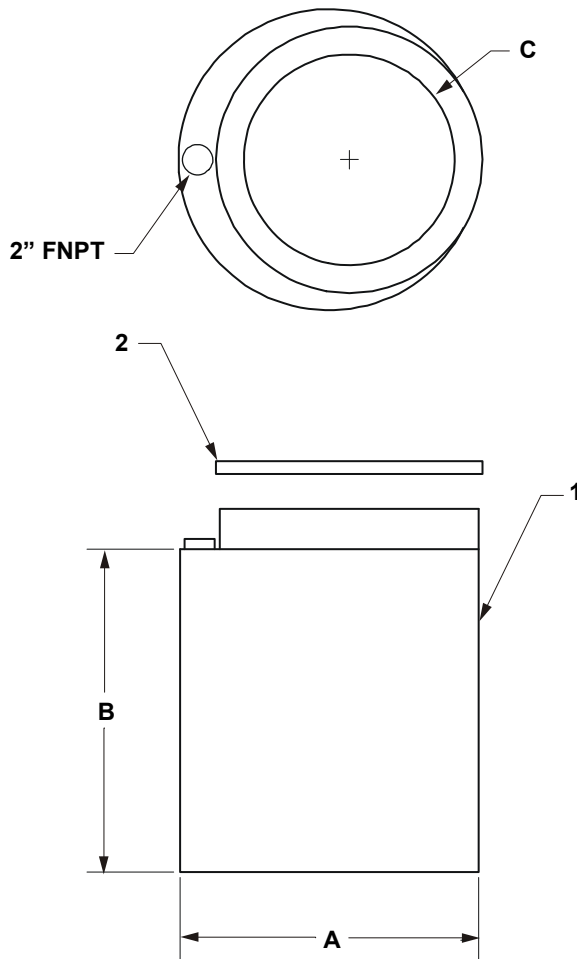

### SPECIFICATIONS

KEY	DESCRIPTION
1	<b>BASIN:</b> Constructed of 1/8" thick yellow polyethylene with 2" FNPT level / viewing port
2	<b>BONNET:</b> Constructed of yellow polyethylene

### DIMENSIONS

KEY	OF-50
A	30" diameter
B	21" height
C	21" diameter
<b>CAPACITY</b>	55 gallons

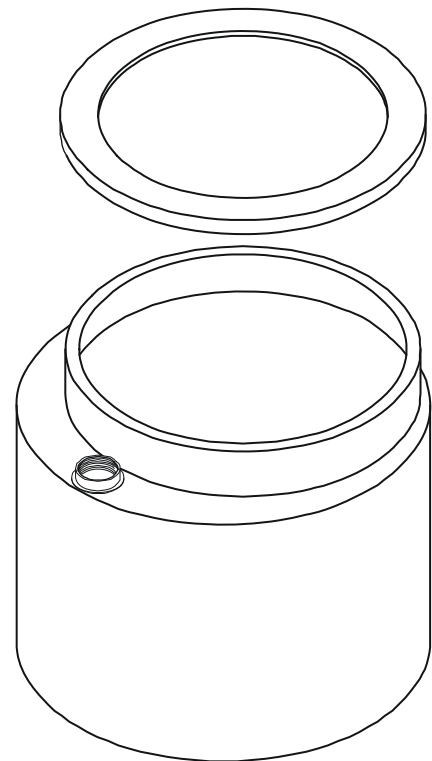

**Note: All dimensions are +/- 1/8". All weights are approximate. All dimensions are subject to change without notice.**

**MANUFACTURING:** Mixers, Bypass Feeders, Filter Feeders, Bromine Feeders, Sample Coolers, Sludge Traps, Separators, Separator Systems, Tank Stands, Tank Package Systems, Glycol Feed Systems, Coupon Racks, Control Stations, NEMA Enclosures, Custom Packaged Systems and Specialty Welding

P.O. Box 6207 | Garden Grove, CA 92846-6207 | 11800 Monarch St. | Garden Grove, CA 92841-2113 | Phone (714) 379-5519 | Fax (714) 379-5549  
Northern California Region | Phone (510) 487-5310 | Southwest Region | Phone (602) 470-1015 | Email: [customerservice@jllwingert.com](mailto:customerservice@jllwingert.com)

[www.jllwingert.com](http://www.jllwingert.com)