

J.L. WINGERT CO.

Specification Sheet SEPARATOR ECONOMY CYCLE TIMER MODEL CT-E

SS052203.D 03/16

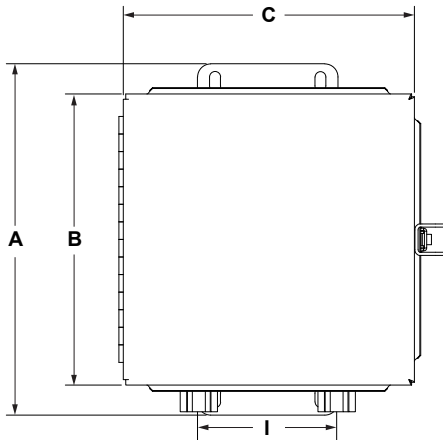

SPECIFICATIONS:

ENCLOSURE	NEMA 3R powder coated carbon steel
TIMING RANGE	OFF TIME: Time period valve is closed: .01 sec to 100 hr
	ON TIME: Time period valve is open: .01 sec to 100 hr
DEFAULT SETTING	OFF TIME: Time period valve is closed: 1 hr
	ON TIME: Time period valve is open: 30 sec
INPUT VOLTAGE	115VAC / 1Ø / 50 / 60Hz
OUTPUT RATING	SPDT 8 amps
OPERATING TEMPERATURE	-4°F to 140°F (-20°C to 60°C)
ELECTRICAL CONNECTIONS	1/2" CONDUIT HUB

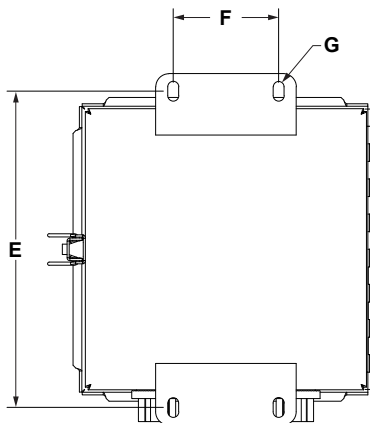

DIMENSIONS:

KEY	DESCRIPTION
A	10"
B	8 1/16"
C	8"
D	6 1/8"
E	9"
F	3"
G	5/16"
H	1 1/2"
I	2 1/2"
WEIGHT	8 lbs.

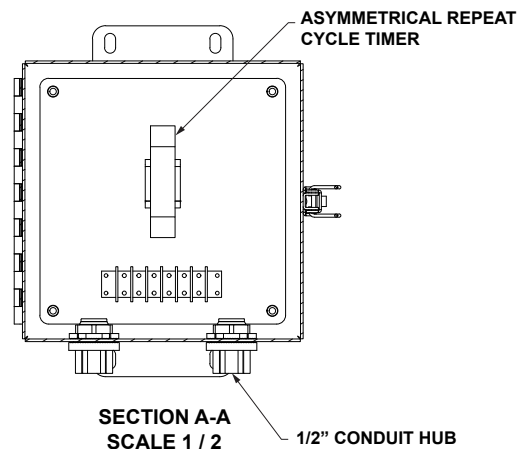
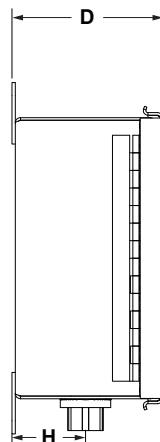

Note: All dimensions are +/- 1/8". All weights are approximate. All dimensions are subject to change without notice.

MANUFACTURING: Mixers, Bypass Feeders, Filter Feeders, Bromine Feeders, Sample Coolers, Sludge Traps, Separators, Separator Systems, Tank Stands, Tank Package Systems, Glycol Feed Systems, Coupon Racks, Control Stations, NEMA Enclosures, Custom Packaged Systems and Specialty Welding

P.O. Box 6207 | Garden Grove, CA 92846-6207 / 11800 Monarch St. | Garden Grove, CA 92841-2113 | Phone (714) 379-5519 | Fax (714) 379-5549
Northern California Region | Phone (510) 487-5310 | Southwest Region | Phone (602) 470-1015 | Email: customerservice@jllwingert.com

www.jllwingert.com