

J.L. WINGERT CO.

Specification Sheet 1/2" TO 3" SEPARATOR REMOVABLE LEGS MODELS RL-[]

SS052013.E 03/16

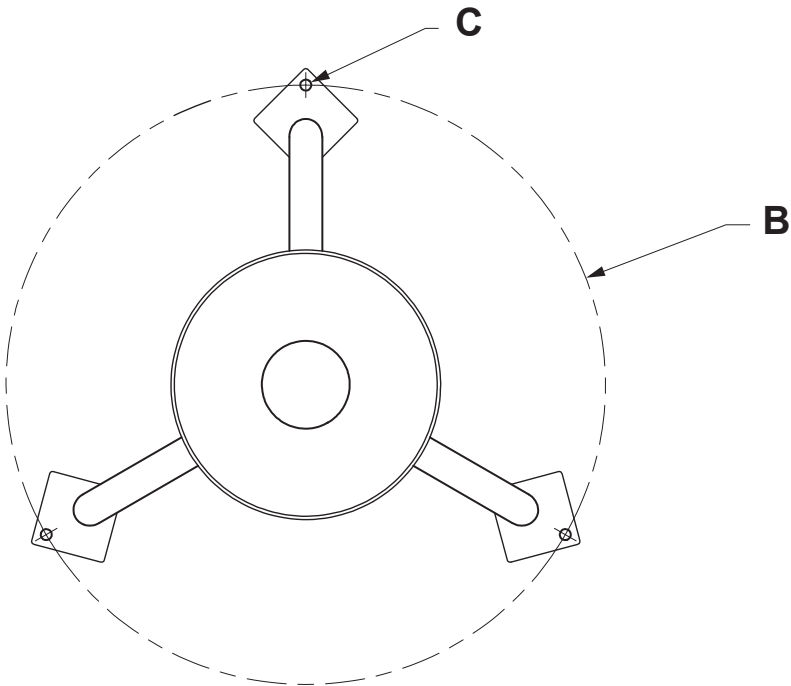

SPECIFICATIONS:

RL-[]	Removable legs are constructed from carbon steel and painted with water based enamel. All hardware is plated steel.
--------	---

DIMENSIONS:

MODEL	A	B	C	WEIGHT
RL-06	13 1/8"	24"	7/16"	11 lbs.
RL-10	13 3/8"	24"	7/16"	13 lbs.

NOTE: RL-06 fits 1/2" to 2 1/2" models "XTI", "XGD" and "XFT" separators. RL-10 fits 3" models "XTI", "XGD" and "XFT" separators.

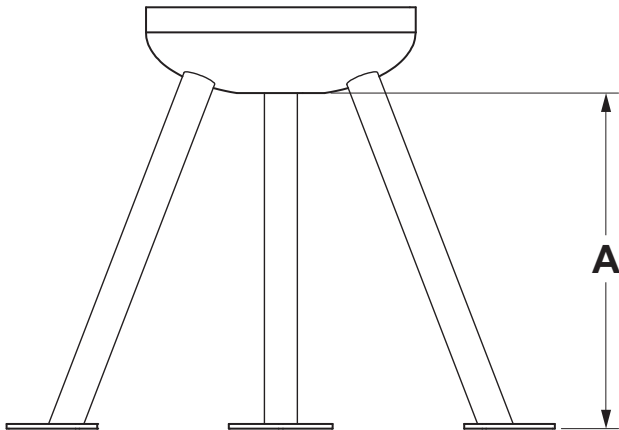

Note: All dimensions are +/- 1/8". All weights are approximate. All dimensions are subject to change without notice.