

# J.L. WINGERT CO.

## Specification Sheet 3" FLANGED, REMOVABLE DOME SEPARATOR MODEL RFL-0300

SS050008.A 03/16

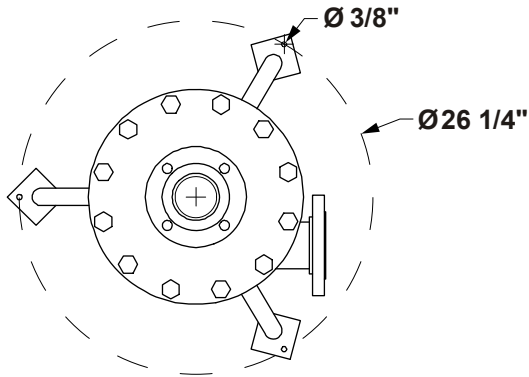

**SPECIFICATIONS:**

<b>RFL-0300</b>	Body is constructed of carbon steel, ANSI 150# RF/SO inlet and outlet flanges and painted with water based enamel. All hardware is plated steel.
-----------------	--

**FLOW RANGE:**

MODEL	4 PSI DROP	12 PSI DROP
RFL-0300	205 GPM	355 GPM

**DIMENSIONS:**

KEY	DESCRIPTION
1	3" flanged inlet
2	3" flanged outlet
3	1 1/2" FNPT drain
<b>WEIGHT</b>	222 lbs
<b>PRESSURE</b>	150 PSI (10.3 bar) max
<b>TEMPERATURE</b>	200° F (93° C) max

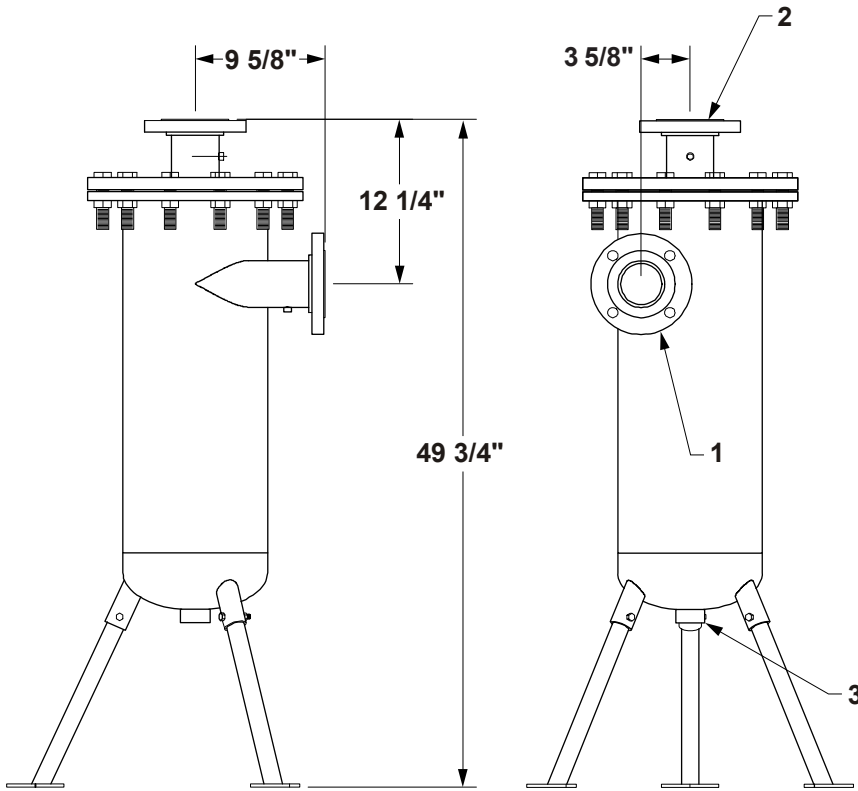

**Note: All dimensions are +/- 1/8". All weights are approximate. All dimensions are subject to change without notice.**

**MANUFACTURING:** Mixers, Bypass Feeders, Filter Feeders, Bromine Feeders, Sample Coolers, Sludge Traps, Separators, Separator Systems, Tank Stands, Tank Package Systems, Glycol Feed Systems, Coupon Racks, Control Stations, NEMA Enclosures, Custom Packaged Systems and Specialty Welding

P.O. Box 6207 | Garden Grove, CA 92846-6207 | 11800 Monarch St. | Garden Grove, CA 92841-2113 | Phone (714) 379-5519 | Fax (714) 379-5549  
Northern California Region | Phone (510) 487-5310 | Southwest Region | Phone (602) 470-1015 | Email: customerservice@jllwingert.com

[www.jllwingert.com](http://www.jllwingert.com)