

J.L. WINGERT CO.

SEPARATOR OPERATION & MAINTENANCE MANUAL



PLEASE RECORD THE FOLLOWING DATA

(Information is located on the product label or packing slip)

Product: _____

Model No: _____

Serial No: _____

Installation Date: _____

Installation Location / Application: _____

The above information will help when ordering replacement parts and accessories for your Wingert Separator.

J.L. WINGERT CO. MANUFACTURED PRODUCTS

Mixers, Bypass Feeders, Filter Feeders, Bromine Feeders, Sample Coolers, Sludge Traps, Separators, Separator Systems, Tank Stands, Tank Package Systems, Glycol Feed Systems, Coupon Racks, Control Stations, Boiler Chemical Feed Systems, NEMA Enclosures, Custom Packaged Systems and Specialty Welding

P.O. Box 6207 • Garden Grove, CA 92846-6207 / 11800 Monarch St. • Garden Grove, CA 92841-2113 • Phone (714) 379-5519 • Fax (714) 379-5549
Northern California Region • Phone (510) 487-5310 • Southwest Region • Phone (602) 470-1015 • Email: customerservice@jllwingert.com

www.jllwingert.com

OM0500.E 12/17

CONTENTS:	PAGE
1.0 INTRODUCTION	2
2.0 WARRANTY	2
3.0 UNPACKING	2
4.0 MODEL NUMBER VERIFICATION	3
5.0 LOCATION AND ENVIRONMENT	4
6.0 SAFETY	4
6.1 SAFETY HIGHLIGHTS	4
7.0 HOW WINGERT SEPARATORS WORK ⁵	5
8.0 INSTALLATION	5
8.1 MOUNTING	5
8.2 INSTALLATION OPTIONS	6
8.2.1 FULL STREAM	6
8.2.2 SIDE STREAM	6
8.2.3 AIR RELEASE (OPTIONAL)	7
9.0 MAINTENANCE	7
10.0 DETERMINING PURGE CYCLES	7
11.0 TROUBLESHOOTING	7
12.0 NOTES	7
13.0 ASSOCIATED PRODUCTS	8

1.0 INTRODUCTION

Thank you for your purchase of your J.L. Wingert Co. Separator. Known for reliability and low-maintenance operation, Wingert Separators are an economical solution for the removal of solids such as sand, dirt, metal chips and sludge from liquid streams. Wingert Separators are ideal for wells, water recycling and other liquid stream applications. The low-maintenance design utilizes no filter media or moving parts. Wingert Separators and Separator Systems are available from 8 to 13,953 GPM with a variety of optional features.

2.0 WARRANTY

Wingert Separators are warranted against manufacturing defects in material and workmanship for one year from the date of shipment. Applications outside the service for which the product is designed, including any non-factory modifications, will automatically void any warranty. Items returned to J.L. Wingert Co. for warranty consideration must be transported via prepaid freight. Final warranty determination will be made upon inspection. J.L. Wingert Co. will, at their discretion, repair or replace any defective item. Any repair or replacement outside warranted limitations will be considered a repair order and quoted accordingly. All replacements will be F.O.B. factory. There are no other implied or expressed warranties.

3.0 UNPACKING

Wingert Separators are fully assembled and ready for installation. A separator may be packed in a carton or shipped secured to a shipping pallet. Inspect packaging upon receipt for any damage. Unpack and inspect the product for damage and verify that goods received correlate with the packing list and product table on page 3. Verify that no packing material has obstructed the inlet, outlet or purge openings. Notify the factory of any discrepancies immediately upon receipt. If any product is damaged due to freight handling, contact the factory immediately for further assistance. It is recommended that photo documentation of any damage or discrepancy be supplied to support any claims.

NOTE: Most freight carriers allow only a limited time after receipt of goods to file a freight claim.

4.0 MODEL NUMBER VERIFICATION

RTE	-0050	/C
-----	-------	----

OPTIONS	
AR	Air release
C	Clean out
L	Low Profile, 22 1/2° installation (XFD Series only)
P	Removable purge chamber
S	Separator built from 316 stainless steel
ASME	Separator built to ASME code

SIZE	
0050	1/2" Separator
0075	3/4" Separator
0100	1" Separator
0125	1 1/4" Separator
0150	1 1/2" Separator
0200	2" Separator
0250	2 1/2" Separator
0300	3" Separator
0400	4" Separator
0500	5" Separator
0600	6" Separator
0800	8" Separator
1000	10" Separator
1200	12" Separator
1400	14" Separator
1600	16" Separator
1800	18" Separator
2000	20" Separator

SERIES	
XTI	Carbon steel separators with flow range from 8 to 355 GPM, inlet and outlet 1/2" to 2 1/2" FNPT, 3" MNPT
XFT	Carbon steel separators with flow range from 8 to 355 GPM, inlet and outlet 1/2" to 3" flanged
RTE	Carbon steel separators with flow range from 8 to 355 GPM, inlet and outlet 1/2" to 2 1/2" FNPT, 3" MNPT, removable dome
RFL	Carbon steel separators with flow range from 8 to 355 GPM, inlet and outlet 1/2" to 3" flanged, removable dome
XGD	Carbon steel separators with flow range from 8 to 355 GPM, inlet and outlet 1/2" to 3" grooved
XFD	Carbon steel separators with flow range from 352 to 13,953 GPM, inlet and outlet 4" to 20" flanged

5.0 LOCATION AND ENVIRONMENT

The low-maintenance design of the Wingert Separator requires periodic inspection. Separators should be accessible from all directions for inspection. Removable dome and optional removable purge chambers will require special clearances. Remote installations should be installed with either an automatic or a continuous purge kit.

6.0 SAFETY

J.L. Wingert Co.'s equipment is designed and built with safety in mind. However, proper installation and operation can increase your overall safety.

DO NOT INSTALL, OPERATE OR REPAIR THIS EQUIPMENT WITHOUT READING THIS MANUAL AND THE SAFETY PRECAUTIONS CONTAINED THROUGHOUT.

BE SURE THAT ALL INSTALLATION, OPERATION, MAINTENANCE AND REPAIR PROCEDURES ARE PERFORMED ONLY BY QUALIFIED INDIVIDUALS.

6.1 SAFETY HIGHLIGHTS

Read and understand the following safety highlights.

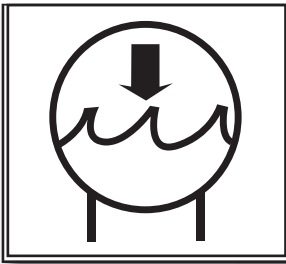

WATER PRESSURE INSIDE THE UNIT

See design specification for maximum operating pressure. Do not perform maintenance or repair without first releasing the pressure and draining the fluid from the unit.



EQUIPMENT IDENTIFICATION LABEL

Identification label provides equipment information. Be sure the voltage, phase and frequency of the input power are as specified on the Equipment Identification Label and conform with your requirements.



7.0 HOW WINGERT SEPARATORS WORK

System effluent passes through the Wingert Separator in a high velocity circular motion. Centrifugal force slings the particulates, sand, debris and sludge outward to the separator wall and downward in a spiral motion. Gravitational force pulls the separated solid particles downward past the spin trap plate into the solids holding chamber. Cleansed effluent then rises through the vortex locator and returns back to the system.

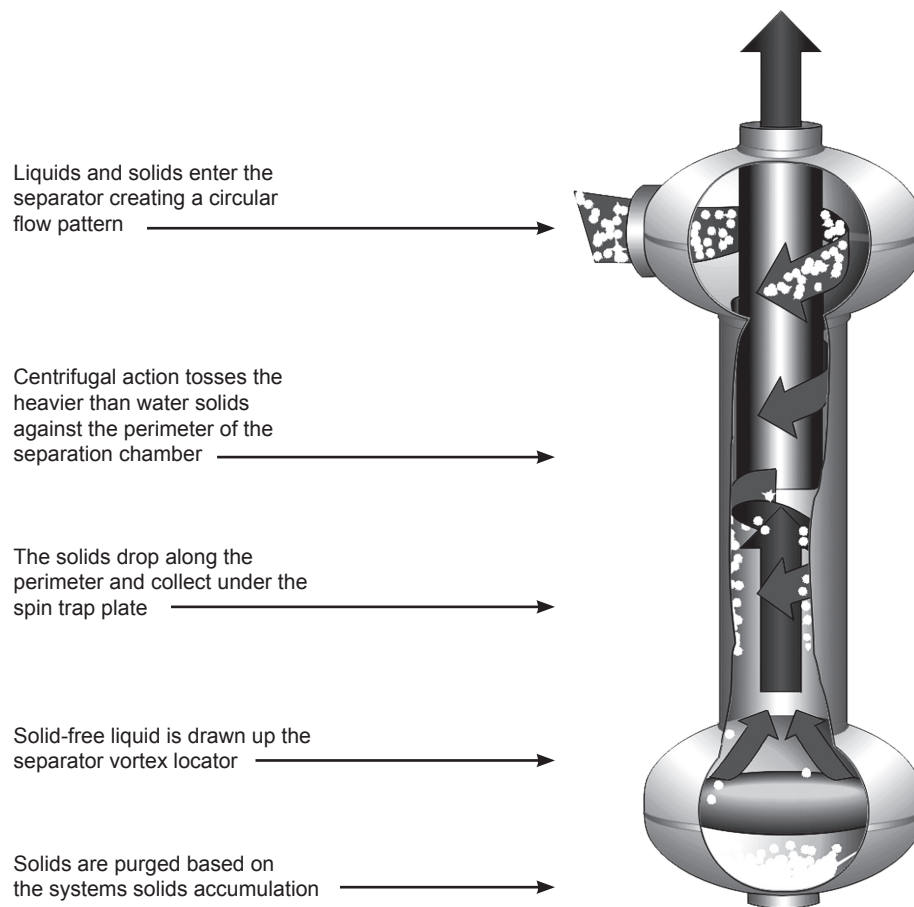

8.0 INSTALLATION

All Wingert Separators must be installed at an angle between 22-1/2 and 90 degrees for maximum efficiency. This provides optimum gravitational force to separate the solids from the liquid stream sending them downward into the solids collection chamber. An installation of less than 22-1/2 degrees may result in solids being pulled back into the cleansed liquid stream negating the functionality of the separator.

8.1 MOUNTING

Check local codes prior to final location and mounting. Some 1/2" to 3" models do not come with bracket mounts or freestanding legs. These options are available from the factory. All separators must be firmly secured and anchored to support the separator and connections when full of liquid.

8.2 INSTALLATION OPTIONS

Based on your application, refer to one of the following installation options:

8.2.1 FULL STREAM:

Installation of the separator in the direct flow stream is the most efficient manner to separate solids. A minimum of 4 PSI and a maximum of 12 PSI pressure drop between inlet and outlet is required. Installation can be a multi-pass flow operation such as in a water tower (Figure 1) or a single pass flow operation (Figure 2) such as irrigation, car wash and well pump applications.

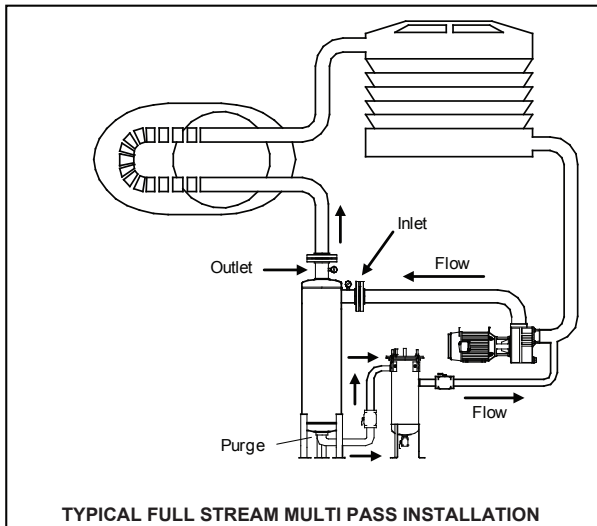

Figure 1

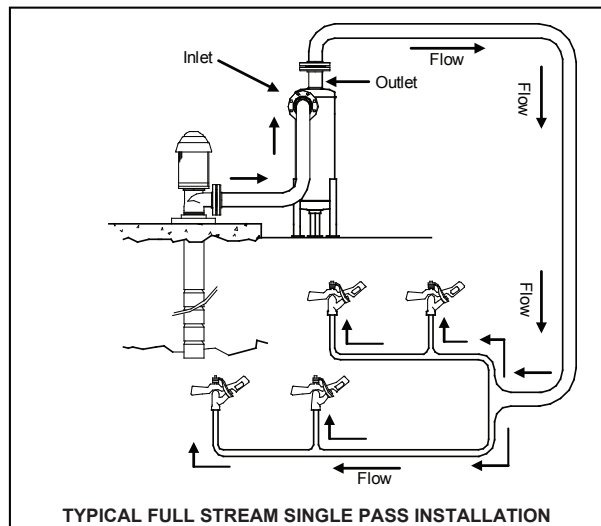

Figure 2

8.2.2 SIDE STREAM:

The side stream application is used where the system is too large or the amount of accumulated solids is minimal. Side stream flow rates range from 10%-20% of the full system flow rate. This installation also requires a 4 PSI to 12 PSI pressure drop between the inlet and outlet for optimum results. If the separator discharge is returned to the system discharge line (Figure 3), the separator must be equipped with a booster pump to attain the required pressure differential. When a booster pump is not used (Figure 4), the side stream discharge must be plumbed to the pump suction or a system throttle valve must be installed between the inlet and outlet of the side stream system to maintain an adequate pressure differential.

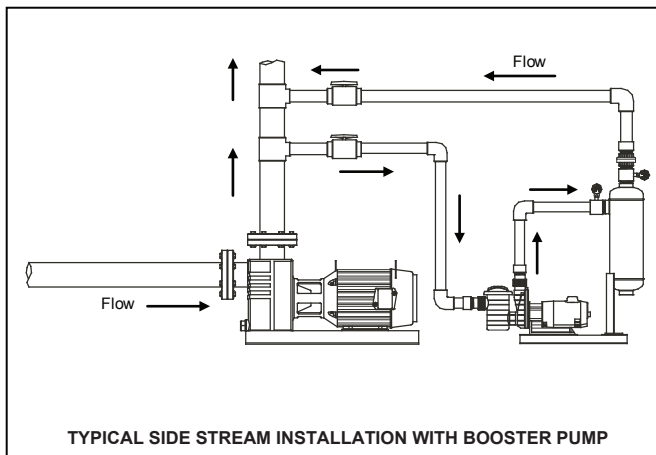

Figure 3

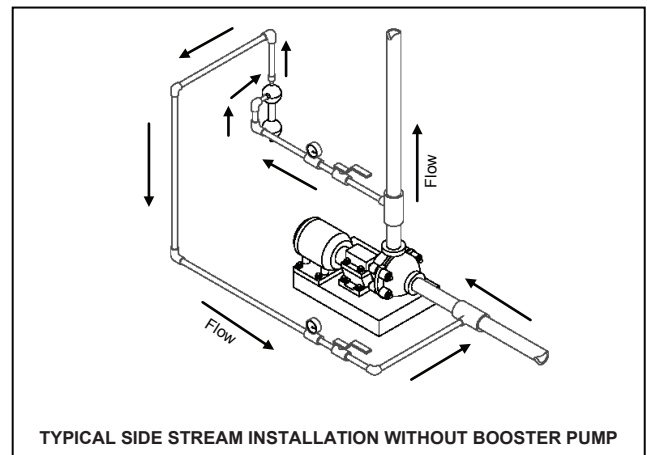

Figure 4

8.2.3 AIR RELEASE (OPTIONAL):

If your separator was ordered with an Option AR (Air Release), open the valve until all air is evacuated and water starts to discharge from the valve. At this point, the air has been purged from the separator.

9.0 MAINTENANCE

Purging of the solids collection chamber is the only maintenance that a Wingert Separator requires. Periodic inspection through inlet and outlet ports of upper chamber for abrasion is recommended depending on the type of solids and volume being filtered.

10.0 DETERMINING PURGE CYCLES

*To determine the necessary frequency, purge often at first; then calculate the rate with regard to the actual volume of separated solids. **Accumulated solids could overflow the collection chamber and adversely affect the separator performance if not purged regularly. Purging varies based on system cleanliness.***

11.0 TROUBLE SHOOTING

SYMPTOM	CAUSE
1. No solids removed	To determine if the solids being missed can be separated, take a sample in a small transparent container, put a lid on and shake the sample. What noticeably settles out in 30 seconds can be removed by a separator on the first pass. What settles in 60 seconds can be separated on a second pass. The particles that do not settle cannot be removed by a separator.
	Check pressure differential. A minimum of 4 PSI pressure drop is required to achieve proper solid/liquid separation. Less than 4 PSI may provide inadequate separation.
	Verify that the purge chamber is not clogged.
2. Leaking	Check that fittings are secure. Threads should be clean of solids build-up and have PTFE sealing tape and/or paste applied. Flange connections need proper bolts with a gasket material for sealing.

12.0 NOTES

13.0 ASSOCIATED PRODUCTS

J.L. WINGERT CO. SEPARATOR ASSOCIATED PRODUCTS

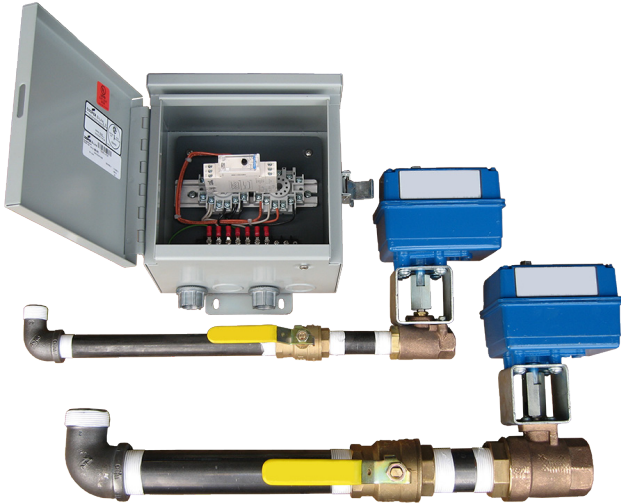

MOTORIZED PURGE KIT

Wingert Motorized Purge Kits come preassembled and ready to install. Motorized purge kits are convenient for remote locations or where frequent purging is required. A motorized purge kit is available in either economy and deluxe models. Motorized purge kits include a manual purge kit, motorized ball valve and a timer.

TOWER BASIN EDUCTORS

Wingert Tower Basin Eductors maximize the system flow rate by creating a flow that is five times the Separator System discharge flow rate allowing the troublesome solids to become suspended and diverted toward the suction piping of the Separator System.

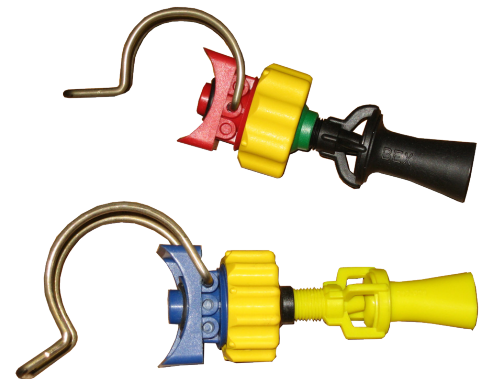

RECOVERY TANKS

Wingert Recovery Tanks allow for the collection of the purged solids and recovery of the water. The recovery tank allows the solids to be captured and the cleaned water to be introduced back into the system saving water from being dumped down the drain. The Recovery Tanks comes in four sizes; 2 gallon, 5 gallon and 10 gallon and can come with an optional Indicator Package to signal when the bag is full.

J.L. WINGERT CO. MANUFACTURED PRODUCTS

Mixers, Bypass Feeders, Filter Feeders, Bromine Feeders, Sample Coolers, Sludge Traps, Separators, Separator Systems, Tank Stands, Tank Package Systems, Glycol Feed Systems, Coupon Racks, Control Stations, Boiler Chemical Feed Systems, NEMA Enclosures, Custom Packaged Systems and Specialty Welding

P.O. Box 6207 • Garden Grove, CA 92846-6207 / 11800 Monarch St. • Garden Grove, CA 92841-2113 • Phone (714) 379-5519 • Fax (714) 379-5549
Northern California Region • Phone (510) 487-5310 • Southwest Region • Phone (602) 470-1015 • Email: customerservice@jllwingert.com

www.jllwingert.com