

# J.L. WINGERT CO.

## Specification Sheet 1-10 GPM FLOW INDICATOR OPTION 07

SS163507.D 03/17

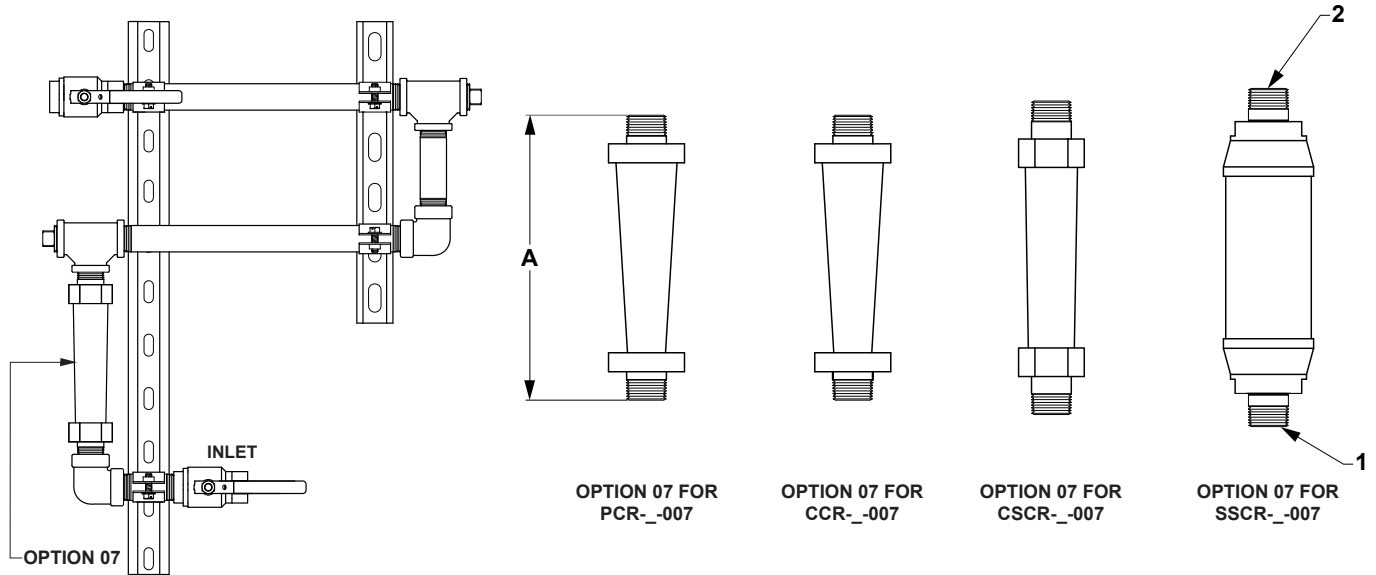

KEY	DESCRIPTION	
1	INLET	3/4" MNPT
2	OUTLET	3/4" MNPT

DIMENSION	MODEL NUMBER			
	PCR-_-007	CCR-_-007	CSCR-_-007	SSCR-_-007
<b>A</b>	7 1/2"	7 1/2"	8 1/4"	8 15/16"
<b>LENGTH ADDER TO COUPON RACK</b>	6 1/2"	6 1/2"	4 1/4"	4 3/4"
<b>WETTED MATERIALS</b>	Body: Polysulfone Guide Rod: 316SS Seals: FKM	Body: Polysulfone Guide Rod: 316SS Seals: FKM	Body: Polysulfone/ Brass Spring: 316SS Seals: BUNA N	Body: 316SS Spring/Rod: 316SS Seals: FKM

TEMPERATURE (°F / °C)	NON-SHOCK PRESSURE RATING							
	PVC		CPVC		Carbon Steel (CS)		316 Stainless Steel (SS)	
	PSI	BAR	PSI	BAR	PSI	BAR	PSI	BAR
73° / 23°	150.0	10.4	175.0	12.1	263.0	18.1	300.0	20.7
90° / 32°	112.5	7.7	150.0	10.3	238.0	16.4	287.0	19.8
110° / 43°	75.0	5.2	125.0	8.6	208.0	14.3	237.0	18.8
130° / 54°	45.0	3.1	100.0	6.9	178.0	12.3	259.0	17.9
150° / 66°	N/A	N/A	76.0	5.2	149.0	10.3	244.0	16.8
200° / 93°	N/A	N/A	N/A	N/A	74.0	5.1	208.0	14.3
250° / 121°	N/A	N/A	N/A	N/A	N/A	N/A	N/A	N/A

Note: All dimensions are +/- 1/8". All dimensions are subject to change without notice.  
See Operation & Maintenance Manual for part numbering.

MANUFACTURING: Mixers, Bypass Feeders, Filter Feeders, Bromine Feeders, Sample Coolers, Sludge Traps, Separators, Separator Systems, Tank Stands, Tank Package Systems, Glycol Feed Systems, Coupon Racks, Control Stations, NEMA Enclosures, Custom Packaged Systems and Specialty Welding

P.O. Box 6207 | Garden Grove, CA 92846-6207 / 11800 Monarch St. | Garden Grove, CA 92841-2113 | Phone (714) 379-5519 | Fax (714) 379-5549  
Northern California Region | Phone (510) 487-5310 | Southwest Region | Phone (602) 470-1015 | Email: customerservice@jllwingert.com

[www.jllwingert.com](http://www.jllwingert.com)